



When it's Done Right...it's Golden!

## Runabout 2 Motor 4 Post Lifts



**Save this manual for future reference!!**

Golden Manufacturing, Inc. 17611 East Street North Fort Myers, Florida 33917  
Phone# 239-337-4141 / Fax# 239-337-4482  
Email: [Sales@GoldenBoatLifts.com](mailto:Sales@GoldenBoatLifts.com)

Dealer: \_\_\_\_\_ Date of Install: \_\_\_\_\_  
Owner: \_\_\_\_\_ Serial# \_\_\_\_\_

## INTRO

Congratulations on your purchase of a Runabout 2 Motor 4 Post Boat Lift. We appreciate your business and want you to know you have purchased the finest Boat Lift on the market today. This Owners Manual is designed to provide vital information on safety, operation and maintenance of your new lift. This owner's manual covers 2 Motor 4 Post Runabout lifts from 4,500 lbs. to 9,000 lbs. Again we thank you for your business and you can have peace of mind knowing your boat is cradled by GOLDEN.

“When It’s Done Right It’s....**Golden!**”



**CAUTION:**  
**Read operating instructions carefully.**

## Precautions Before Operating The Lift System

- Never leave the lift unattended while in operation
- Be sure the boat stays level when raising or lowering the boat
- Do not run the cradles down allowing the cables to go slack
- If the cables go slack be sure to realign and tighten the cables before lifting the boat.
- Keep hands clear of moving parts
- Do not exceed the rated capacity
- Boat lifts are not intended for lifting humans
- Do not operate the boat lift without a G.F.C.I.
- (The lift must be wired by a licensed electrician)
- Inspect and lubricate all grease fittings periodically
- Inspect the cables before each use
- The boat lift must be operated by an adult
- Be sure the center of gravity of your boat is in the center of the lift
- Do not operate the lift without the protective covers in place
- **DO NOT WORK ON YOUR BOAT OR GO UNDER IT WHEN THE BOAT IS ON THE LIFT**

**YOU MUST COMPLY WITH THE WARNINGS TO PREVENT INJURY TO A PERSON OR DAMAGE TO YOUR BOAT.**

## BOAT LIFT MAINTENANCE

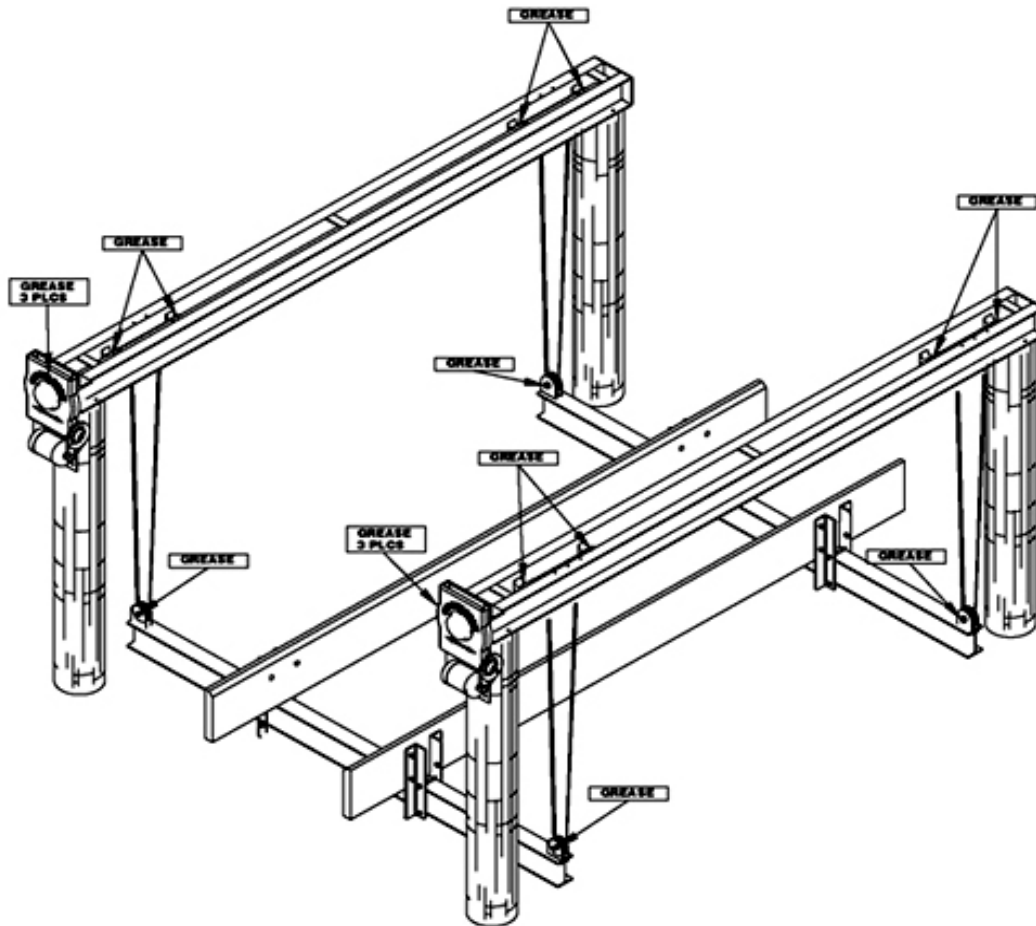

### To keep your lift in operating service:

- 1) Grease all fittings including the three (3) behind the motor cover with a high temperature (550) water resistant high impact grease. Wipe excess grease from all zerk fittings.
- 2) Inspect all stainless steel braided cable for fraying and kinking. Replace any and all frayed or kinked cable.
- 3) Inspect all electrical cable and connections. Be sure the ground fault interrupter is operable. Reconnect & tighten any loose connections and promptly replace any frayed or damaged wiring.
- 4) Wipe all exposed aluminum lift surfaces.
- 5) Rinse cables, rollers and all submersible parts after each use.

## Weight Distribution

- The weight of your boat should be evenly distributed on the beams to ensure your safety and longevity of your lift. Consult the boat manufacturer for the lifting points and the center of gravity on your boat.
- Always place the center of gravity of your boat directly in the CENTER of your cradle beams.
- Please consult with your installer for assistance and proper placement of your boat on the lift.
- See illustration below for further instructions on loading your 4 Piling Boat Lift.

