

GOLDEN ENGINEERED 4 POST, 2 MOTOR SEA DRIVE BOAT LIFTS

PILE SPACING CHART
The boat center of gravity needs to be set in the center of the top beam

Lift Capacity	"1" Dimension	"2" Dimension	Recommended Pile Diameters
	Lb.	Ft.	
5,000	11	10	8
7,500	12	12	
10,000		12.5	10
14,000		14	
16,000			
20,000	14	16	
24,000	16		

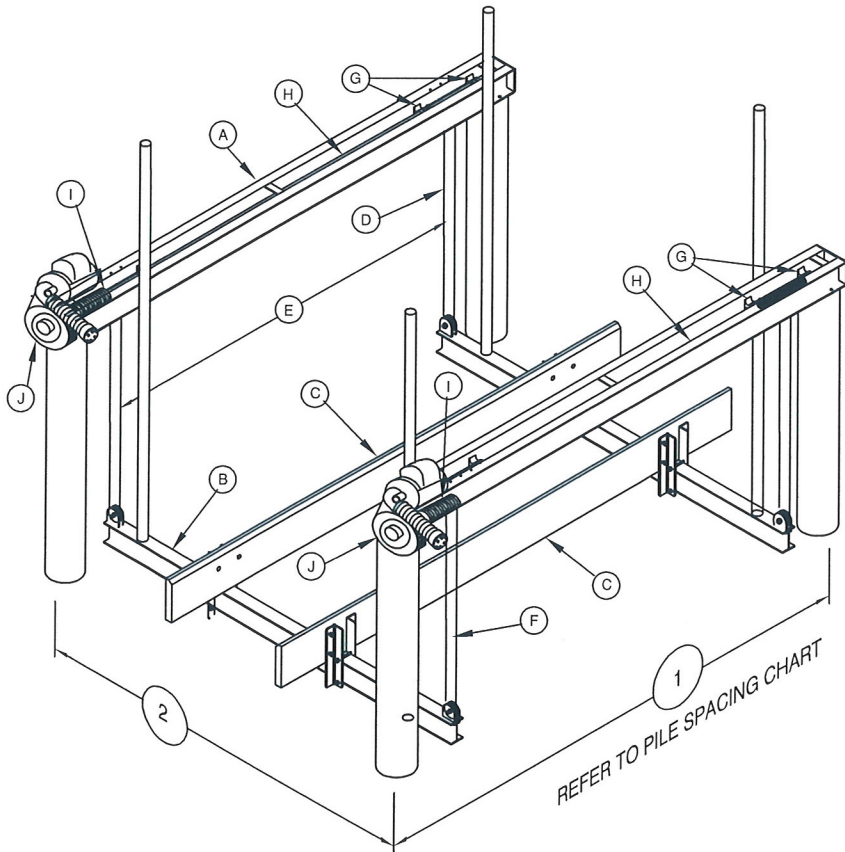

STRUCTURAL ENGINEERING REVIEW

THIS CONSTRUCTION HAS BEEN DESIGNED AS A MAIN WIND FORCE RESISTING SYSTEM, WITH CALCULATED GRAVITY AND WIND LOADS IN COMPLIANCE WITH THE FLORIDA BUILDING CODE 2007, WITH 2009 SUPPLEMENTS, SECTION 1609, ADM 2005, AND ASCE 7-05 "MINIMUM DESIGN LOADS FOR BUILDINGS AND OTHER STRUCTURES" TO WITHSTAND THE WIND LOADS ASSOCIATED WITH A BASIC WIND SPEED OF 150 MPH, EXPOSURE "C". ARNOLD/SANDERS CONSULTING ENGINEERS HAS NO CONTROL OF THE MANUFACTURING, PERFORMANCE, OR INSTALLATION OF THIS PRODUCT. THESE GENERIC PLANS WERE ENGINEERED IN ACCORDANCE WITH ACCEPTED ENGINEERING PRACTICES AND DATA PROVIDED BY THE MANUFACTURER

J.L. Sanders
20-10-11

Arnold/Sanders Consulting Engineers, Inc. J.L. SANDERS
Certificate of Authorization 9451 Reg. Florida No.66391
16881 McGregor Blvd. Suite 102, Ft. Myers, FL 33908 Date:
239-267-3666 Fax:239-267-2771
SIGNATURE NOT VALID WITHOUT RAISED SEAL

STAINLESS STEEL PILING MOUNT BRACKET, 4-3/8" STAINLESS STEEL LAG SCREWS USED TO CONNECT THE BRACKETS TO THE PILING AND 2-3/8" CARRIAGE BOLTS USED TO CONNECT THE BRACKETS TO THE LIFT CHANNELS



NOTE: THIS STRUCTURE WILL WITHSTAND WIND LOADS ASSOCIATED WITH BASIC WIND SPEEDS OF 150MPH CALCULATED PER F.B.C. 2007 AND ASCE 7-05. BOATS SHALL NOT BE STORED ON LIFT DURING HIGH WIND EVENTS

IN GENERAL, PILING PENETRATION TO BE 10' INTO THE SAND BOTTOM OR 5' INTO THE ROCK STRATA. SUB-SURFACE CONDITIONS CAN VARY GREATLY, THE CONTRACTOR SHALL VERIFY ALL PILE CAPACITIES. ALL PILING TO BE 2.5 C.C.A. PRESSURE TREATED WOOD.

- (A) (B) (C) (D) (E) (F) (G) (H) (I) (J)

LIFT CAPACITY	TOP BEAM CHANNEL 2 EACH	CRADLE I-BEAM 2 EACH	BUNK BOARDS (PT)	CABLE SIZE	CABLE SPREAD	GUIDE POST HGTH	BRGS	DRIVE SHAFT	WINDER DIA	MOTOR HP VOLTAGE	INCHES OF LIFT PER MIN	RECOM PILING SIZES
Lbs	INCHES	INCHES		INCHES	IN							
5,000#	4 H x .15 2 W x .23 140" OAL	6 H x .19 4 W x .29 120" LGTH	2x8x144 ROUGH SAWN CARPETED	4 - 5/16" x15' ST ST 1 PART	98"	80"	10 - 2" H.D. EXTRUDED 6061-T6 ALUM.	1-15/16" DIA. SCH 40 GALV PIPE	3-1/2" DIA SCH 80 ALUM PIPE W/ CABLE GROOVES	2 - 3/4 HP 120V/20A 240V/10A	39.70"	8" DIA
7,500#	5 H x .15 2.25 W x .28 x 153" OAL	6 H x .19 4 W x .29 144" LGTH		4 - 5/16" x30' ST ST 2 PART	110"					2 - 1 HP 120V/20A 240V/10A		
10,000#	6 H x .17 2.5 W x .29 x 153" OAL	8 H x .23 5 W x .35 150" LGTH								2 - 3/4 HP 120V/20A 240V/10A		
14,000#	7 H x .17 2.75 W x .29 x 153" OAL	8 H x .25 5 W x .41 150" LGTH	3x10x192 ROUGH SAWN CARPETED	4 - 5/16" x45' ST ST 3 PART	122"	120"	1-15/16" DIA. SCH 80 GALV PIPE	3-1/2" DIA SCH 80 ALUM PIPE W/ CABLE GROOVES	2 - 1 HP 120V/20A 240V/10A	19.85"	10" DIA	
16,000#	8 H x .19 3 W x .35 x 153" OAL	10 H x .25 6 W x .41 168" LGTH										
20,000#	8 H x .25 3.75 W x .41 x 177" OAL	10 H x .25 6 W x .41 192" LGTH										
24,000#	8 H x .25 3.75 W x .41 x 201" OAL	10 H x .29 6 W x .50 192" LGTH			134"				2 - 1 HP 120V/20A 240V/10A	13.20"		